

# Framework for realizing Mobile and Computer Communications through Color Signals

Rajarshi Sanyal  
Engineering Work Center – Wireless  
Reliance Infocomm - India

*Abstract: This paper proposes a technology for realizing a mobile network based on color signals which does not require the time and the space switching matrix for call routing. In absence of the Mobile Switching Center, the call processing is actuated by a color server which synthesizes color signals and transreceives the data as video broadcast signal. The proposed system is based on adaptive color technology. Unlike the existing methods of switching or time multiplexing, this is dependent on a process that can be best described as a multicast method based on color clamping. Each Mobile Station is identified by, and can clamp on to, a specific hue (tinge) and a band of saturation level (how much white is mixed with the color). The Voice information is transcoded within this band of saturation level which is tied up with the specific hue that has been assigned to the mobile subscriber and is further carried by the chrominance signal. The same technology can be used for realizing a Wireless Computer Network which transreceives Information in terms of color without involving IP switching and routing. The technology can be built on the existing methodologies of television transmission .*

## Key Words

Color Server  
Mobile Station (MS)  
International Mobile Subscriber Identity (IMSI)  
Mobile Directory Number (MDN)  
Video Base Transceiver Station (V-BTS)  
Video Base Station Controller (V- BSC)

## 1.0 Introduction

The cellular mobile network consists of the core and the access network. The core network comprises the Mobile Switching Center (MSC), the Visitor Location Register (VLR) and network adjuncts, namely the Home Location Register (HLR), SMS Center, Intelligent Network (IN) and the Value Added Service Platforms. The existing TDM based hardware switching systems are gradually being evolved into Software based Switching Systems known as Soft Switches. According to the existing cellular network topology, the access network area is logically segmented into orthogonal cells. A cluster of cells, forming a larger area, served by a mobile switch is called a Location Area. The radio network (Access Network) consists of the BTS and the BSC interfaced to the MSC on Interoperability Specification [IOS] (CDMA) / BSSAP (GSM) protocol. For Mobility Management, the BTS and the Mobile Station periodically exchange signaling messages based on the CDMA2000 / GSM Air Interface standards.

A mobile station is identified in the network by the IMSI / MIN, either burnt in the MS or programmed in the SIM. The MIN/IMSI is associated with the MDN/MSISDN in the profile of the subscriber created in the HLR while provisioning.

As technology advances, newer access methods are introduced. To name a few on the CDMA side are EV-DO and EV-DV. From the GSM side, we have the HSDPA evolved from the UMTS and the GERAN evolved from the EDGE. As data rates are improving with newer technologies, the Shannon Limit is approached, which is why there is a need of technology that looks beyond the available air interface methodologies.

The proposed mobile network is not based on a cellular approach, and it thrives on video broadcast technique. The network coverage area is not mapped into cells, but is comprised of broader Location Areas. This implies lesser signaling overhead. The access network is formed by dumb repeaters with non-discrete addresses (unlike GSM or CDMA), which lessens the hassle of mobility management in the access and core networks elements.

This paper focuses on the use of the technology for mobile networks and brings out its applicability to wireless computer networking.

## 2.0. Color as the Identity and Carrier

In a typical color circle, the phase of the color vector determines the hue, and the amplitude of the vector depicts the amount of white mixed with the color, i.e. the saturation level of the color. The amplitude modulation across the same color vector results in a modulated saturation level which, if viewed in a scope, will display a specific hue with variations in white mixed with the hue, say for example, light red, dark red, etc.

The technology proposes to use color for two purposes.

1. Identity of a mobile station (address of the mobile station) in a network by a specific hue and a base band saturation level.
2. Carrying the voice and the signaling information by means of amplitude modulation of the color vector within the band of saturation level allotted for the subscriber.

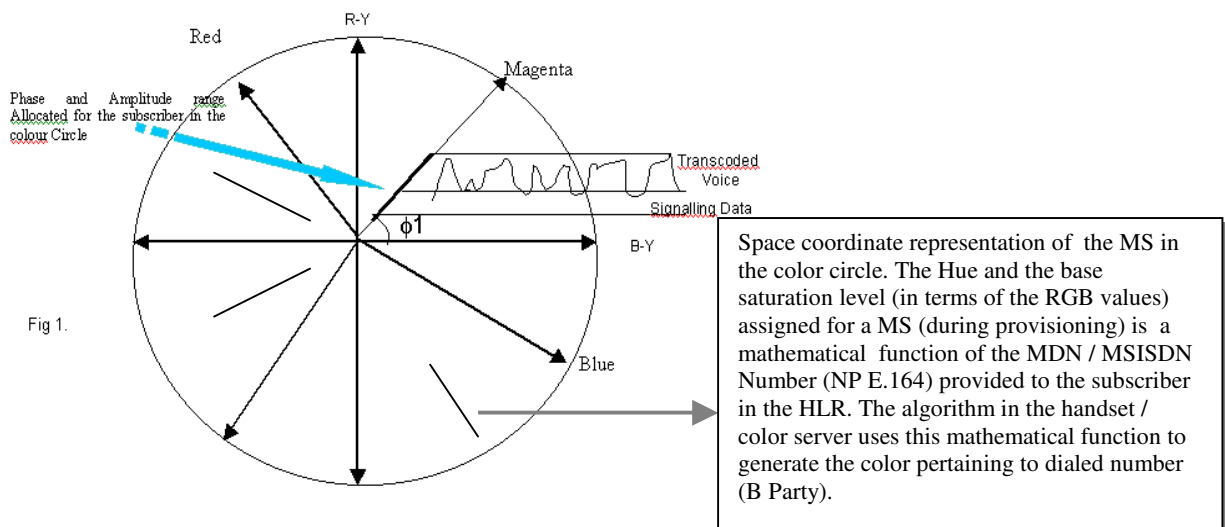

When MS is provisioned for using the services of the given mobile network, it gets the ability to clamp on to only a specific hue (tinge) and a band of saturation levels that is assigned for the subscriber. The tinge with the base saturation level is internally mapped to a particular MDN / MSISDN (E.164 NP) and IMSI/MIN (E.212 NP). There might be multiple MS placed in the same color vector, with each MS having its own band of allotted saturation level. The handset / color

server (discussed later) has the ability to generate any color information according to the B party number it dials. In fact, the color generated will be a function of the dialed E.164 number, which the handset / color server computes and is further processed (Sanyal, 2006).

The color spectrum in terms of the raw Red Green Blue (RGB) analogue output can formulate 16 Million Color combinations. Leaving some headroom for the electrical losses, around 14 million colors can be considered. However, with advanced video technologies like YPbPr (analogue) or YCbCr (digital 8 bit representation of color used at present for MPEG compression), many more color combinations can be realized (ITU-R BT.709-4). The 1080i HDTV technology can be used for the implementation of the color circle. The following analysis provides a figure for the number of simultaneous users that can communicate at a given point of time on a single chroma channel.

The Sample rate for 1080i HDTV is 74.25 Mhz . Let us assume that the speech will be transcoded at a frequency of 8 Khz (using suitable compression techniques) . Hence ,the total number of subscribers that can simultaneously communicate at a given point of time on the color circle (on a single channel / carrier frequency ) with the 1080i HDTV technology =  $74.25 \times 10^3 / 8 = 9280$ .

For the sake of simplicity and to introduce the basic technology, the conventional RGB methodology based on PAL standards will be considered in this paper.

In a color television, a composite color video signal is first split up into color difference signals (color minus the illuminance) and is then finally added up with the illuminance signal by the RGB Matrix to form the RGB voltage levels.

The equation of the illuminance signal (Y) is

$$Y = 0.30 R + 0.59 G + 0.11 B$$

Hence  $R - Y = 0.7R - 0.59G - 0.11B$   
 $R - Y$  is maximum when G and B are 0.  
 Similarly,  $B - Y = 0.89B - 0.59G - 0.3 R$   
 $B - Y$  is maximum when G and R are 0.

In a situation when only (say) red color is generated with an input voltage of 1 volt, the magnitude of the chrominance signal (which depicts the saturation level) shall be

$$|C| = \sqrt{(R-Y)^2 + (B-Y)^2}$$

$$= 0.76v$$

The phase angle of the color vector which governs the hue is

$$\Phi = \tan^{-1} (R-Y) / (B-Y)$$

$$= - 66.80^\circ$$

### 3.0 Wireless Computer Network

The identity of the computer node (i.e. the IP Address, subnet mask, MAC Address and other associated parameters of the computer and the peripherals) can be encoded in terms of digitized color information and broadcast in the UHF by a digital video transceiver (Sanyal Pat. No. 188052, 1995). The color server formulates the chrominance signal, which carries the data addresses for each and individual node within the band of saturation level assigned for the node. The ASCII user data are channelized through a separate band of saturation level allotted on the same color vector. The Color server sums up the color information from different nodes and transmits as video broadcast signal. The recipient node identifies and filters out the information meant for itself and processes it accordingly.

## 4.0 Network Architecture for a Mobile Network

The proposed network is not based on a cellular topology. The BTS is replaced by Video Transceivers placed all over the network coverage area, which can establish an Uplink and Downlink channel in UHF / VHF with the handsets. For convenience, this aforementioned Video Transceiver will be termed as V-BTS.

The chrominance signal transmitted from the V- BTS is primarily a broadcast signal containing millions of color information for all its users in a given network coverage area. Each handset after receiving the chrominance signal demodulates it and filters out the color signal (in terms of R – G – B Levels) pertaining to the specific hue and the band of the saturation level in digitized form. Within the specific band of the saturation level allotted for the subscriber, say Band A (ranges 20% to 45 % ), a specific sublevel, say, Band A1 carries the signaling information (for paging, Alert with Info, etc) and the Band A2, carries the digitized voice information.

The heart of the network is a color server which processes all the color information. The functional details, internal hardware / software architecture and the interoperability with the other network elements has been described in the subsequent sections.

Given below is a high-level network architecture showing the essential network components of the access and core network.

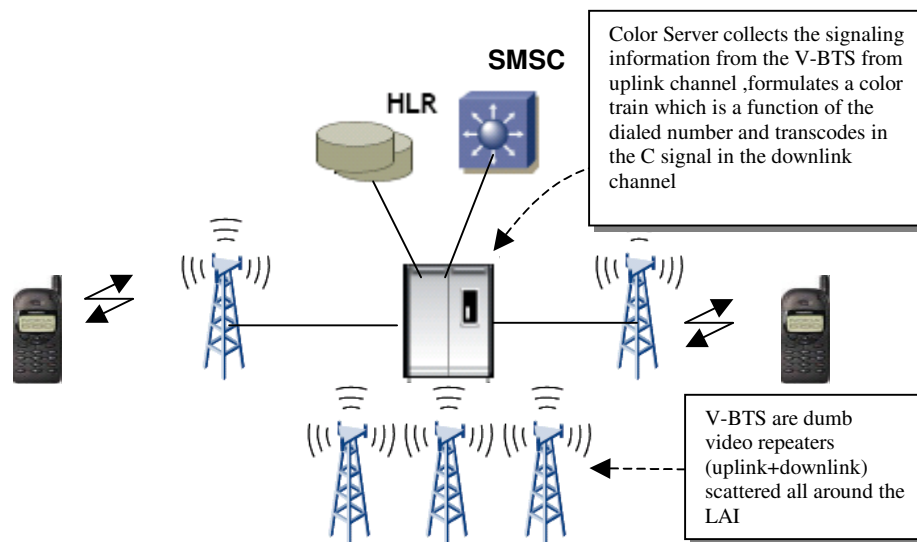

Fig.2. High Level Network Architecture Showing a Color Server catering a single Location Area

### 4.1 Functional Specification of the Mobile station

At a high level, the functional block of the MS can be categorized into four sections, which are further branched out to subsections.

- NAM & SIM Holder Interface – Number Assignment module which stores all the MS related parameters, like MIN/IMSI, MDN, Channel Frequency (UHF or VHF)
- Color Generator and transmitter: Mainly used for making an outgoing call and to enable full duplex communication while in a call.
  - E.164 Number to Hue and saturation level converter for generation of the color as a function of the B Party Number (Dialed Number)
  - Video (PAL) Encoder
  - Phase Shifter
  - Video UHF/VHF Transmitter
- Color Receiver
  - Video (PAL) Transreceiver
  - Phase Detector
- Logic module: to invoke and respond to different signaling messages and accordingly decide to make or break the speech circuit.
- Audio Unit
  - Audio PreAmp & AMP
  - Audio to RGB Transcoder and vice versa
  - AM Bandpass Filter
- Keyboard Encoder
- Display Unit: LCD Display Unit
- Power Supply Unit

Note: The Functional Units in the handsets to process the supplementary services (say CLI) and non voice telephony or bearer services as applicable today in the GSM or CDMA scenario have not covered in this paper.

### Block Diagram of the Mobile Station

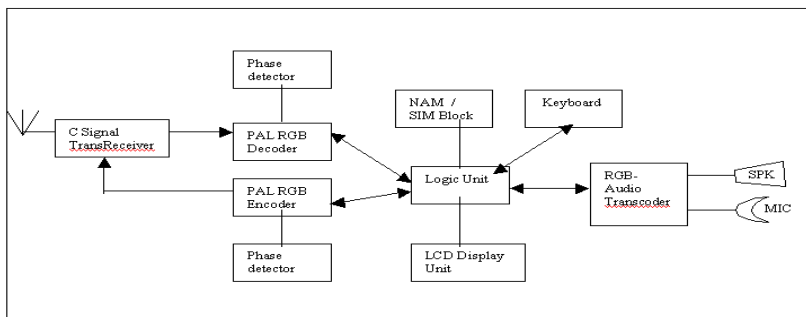

Fig 3

### Block diagram of Keyboard encoder

For a closed user type deployment , in small standalone networks (not interfaced to external networks) , the handset directly computes the color information according to the B party dialed and is further processed by the color server . When a number is dialed the subcarrier frequency (4.43 Mhz) is passed through an amplitude modulator (to actuate the saturation level) and is phase shifted (to form the hue) by a phase shifter to synthesize the desired C signal which is a function of the dialed number. The amplitude and the phase is determined by a logic unit (as shown in the diagram in Fig. 8) which is interfaced to the keyboard generator.

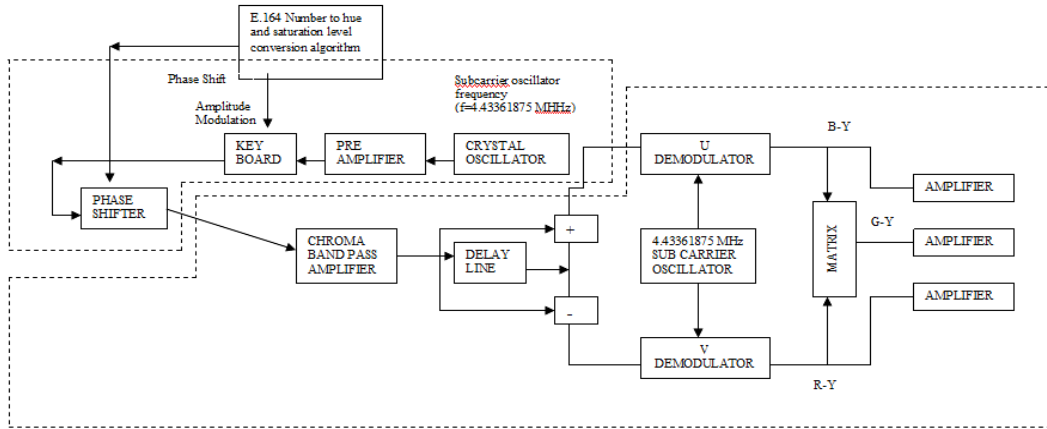

Fig 4 .

## 4.2 Functional specification of the Color Server

For a typical mobile network deployment , when a A Party dials the B party number (B party is a mobile subscriber) for Placing an outgoing call , the 'Origination Message' (AI) carries the signaling information which is received by the color server. The color server has the Dialing plan and computes the Hue and Saturation level pertaining to the B party and generates the page message (AI) accordingly.

The primary functions of the color server are the following.

- Performs all the color signal processing for the access network
- Formulates the color train which is a function of the E.164 Number.
- Performs the Signaling operations (on SS7) with the core network
- Interfaces with the Legacy Networks (on associated mode of signaling and PCM Voice trunks on F Links and on A links on quasi associated mode ).
- Call Data Record generation for Mediation / Billing
- Call routing for the legacy network
- SSP Functionality for Intelligent network operations

### High Level Block Diagram of Color Server

Video Tx Rx	SSP Functionality	Database for Dialing Plan and routing database for call routing to Legacy Networks	Video Encoding and decoding Functionalities	Processing Functionality for SS7 signaling
E.164 Number to C Signal converter	Processing Functionality for color information		Authentication Center	PCM Interface for voice

Fig 5.

## 5.0 Call Flow: Subscriber A in network A1 calls a subscriber B in network A1 and call is established (ANSI 41 / ITU-T MAP)

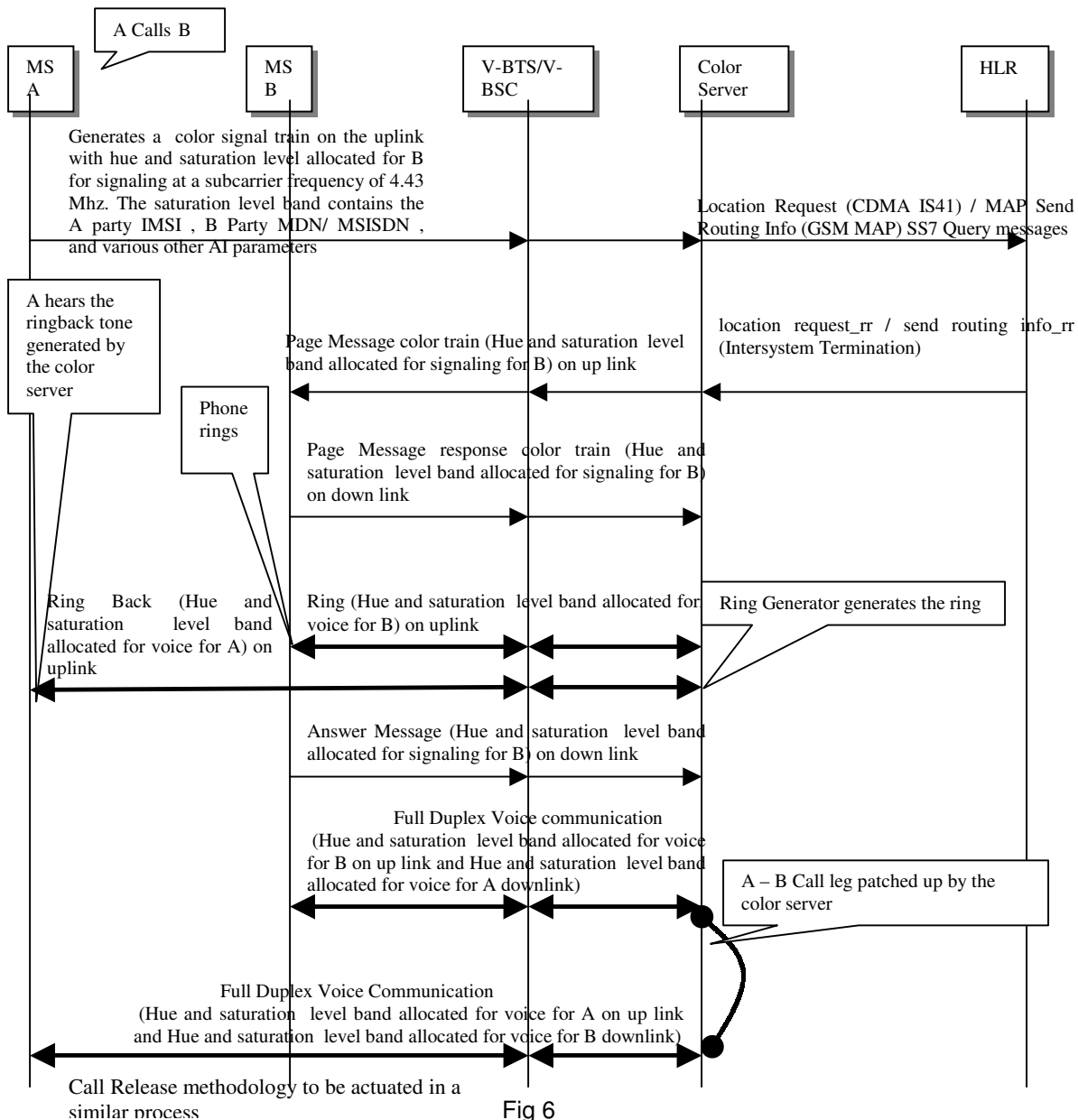

Fig 6

## 6.0 References

- [1] Sanyal, Rajarshi : "A system of wireless networking of computers in the UHF", Patent Document (Pat. No. 188052, Govt of India, October 1995)
- [2] Sanyal, Rajarshi : "Framework for Realizing Mobile Network Through Color Signals" Patent App. No. 0163/MUM/2006, Govt. of India, February 2006).
- [3] ANSI 41 – D Specification / ITU-T MAP 2 Specification
- [4] ITU-R BT.709-4 recommendations